

**Autonics**

**Color Mark Sensor  
BC SERIES**

**INSTRUCTION MANUAL**



Thank you for choosing our Autonics product.

Please read the following safety considerations before use.

**■ Safety Considerations**

※Please observe all safety considerations for safe and proper product operation to avoid hazards.

※⚠ symbol represents caution due to special circumstances in which hazards may occur.

**⚠ Warning** Failure to follow these instructions may result in serious injury or death.

**⚠ Caution** Failure to follow these instructions may result in personal injury or product damage.

**⚠ Warning**

1. **Fail-safe device must be installed when using the unit with machinery that may cause serious injury or substantial economic loss.** (e.g. nuclear power control, medical equipment, ships, vehicles, railways, aircraft, combustion apparatus, safety equipment, crime/disaster prevention devices, etc.)

Failure to follow this instruction may result in personal injury, economic loss or fire.

2. **Do not use the unit in the place where flammable/explosive/corrosive gas, high humidity, direct sunlight, radiant heat, vibration, impact, or salinity may be present.**

Failure to follow this instruction may result in explosion or fire.

3. **Do not disassemble or modify the unit.**

Failure to follow this instruction may result in fire.

4. **Do not connect, repair, or inspect the unit while connected to a power source.**

Failure to follow this instruction may result in fire.

5. **Check 'Connections' before wiring.**

Failure to follow this instruction may result in fire.

**⚠ Caution**

1. **Use the unit within the rated specifications.**

Failure to follow this instruction may result in fire or product damage.

2. **Use dry cloth to clean the unit, and do not use water or organic solvent.**

Failure to follow this instruction may result in fire.

**■ Model**

Model	Item	Sensing distance	Sensing method	Power supply	Output type	Connection	Control output
BC15-LDT-C	Color mark sensor	15mm	Convergent reflective type	12-24VDC	Solid state output (transistor)	Connector type	NPN open collector output
BC15-LDT-C-P							PNP open collector output

**■ Control Output Circuit Diagram**

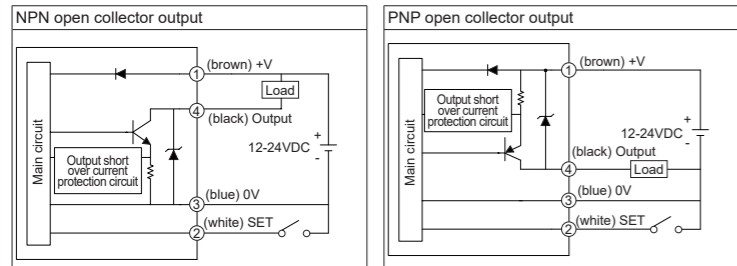

※If short-circuit the control output terminal or supply current over the rated specification, normal control signal is not output due to the output short over current protection circuit.

**■ Connections for Connector Part**

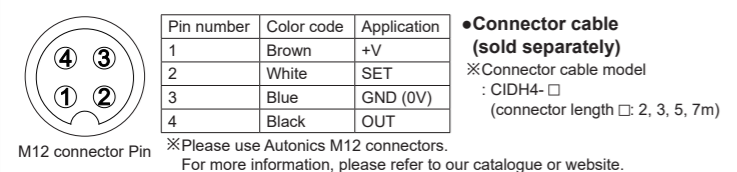

※The above specifications are subject to change and some models may be discontinued without notice.

※Be sure to follow cautions written in the instruction manual and the technical descriptions (catalog, homepage).

**■ Specifications**

Model	BC15-LDT-C	BC15-LDT-C-P
Sensing method	Convergent reflective type	
Sensing distance	15mm ±2mm	
Sensing target	Opaque, Translucent	
Hysteresis	Max. 20% of sensing distance (may vary by sensing mode or sensitivity)	
Spot size	1.24×6.7mm (rectangular)	
Response time	500μs	
Power supply	12-24VDC±10% (ripple P-P: max. 10%)	
Current consumption	Max. 30mA	
Light source	Full Color LED (red, green, blue)	
Sensing mode	C (color only) mode, C+I (color + intensity) mode	
Output mode	Color match output, color mismatch output	
Output timer	40ms OFF delay timer function	
Control output	NPN or PNP open collector output Load voltage: max. 30VDC± Load current: max. 100mA Residual voltage - NPN: max. 1VDC±, PNP: max. 2.5VDC	
Protection circuit	Reverse polarity protection, output short over current protection	
Indicator	Operation indicator: Red LED, Stability indicator: Green LED, Teaching indicator: Full Color LED	
Connection method	Connector type	
External input	External SET cable input	
Insulation resistance	Over 20MΩ (at 500VDC megger)	
Noise immunity	±240V of square wave noise (pulse width:1 μs) from the noise simulator	
Dielectric strength	1,000VAC at 50/60Hz for 1minute	
Vibration	1.5mm amplitude at 10 to 55Hz frequency in each X, Y, Z direction for 2 hours	
Shock	500m/s <sup>2</sup> (approx. 50G) in each X, Y, Z direction for 3 times	
Environment	Incandescent lamp: Max. 3,000lx (receiver illumination) Ambient temp. -10 to 55°C, storage: -25 to 75°C Ambient humi. 35 to 85%RH, storage: 35 to 85%RH	
Protection structure	IP67 (IEC standard)	
Material	Case: Polycarbonate, Sensing part: Acrylic, Bracket: SUS304 (steel use stainless 304), Bolt: Carbon steel	
Accessories	Bracket, M3 bolts: 2, Adjustment screwdriver: 1	
Approval	CE	
Weight <sup>※1</sup>	Approx. 80g (approx. 14g)	

※1: The weight includes packaging. The weight in parenthesis is for unit only.  
※The temperature and humidity of environment resistance is rated at non-freezing or condensation.

**■ Unit Description**

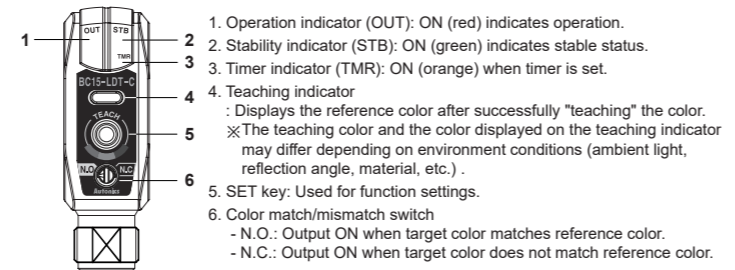

**■ Dimensions**

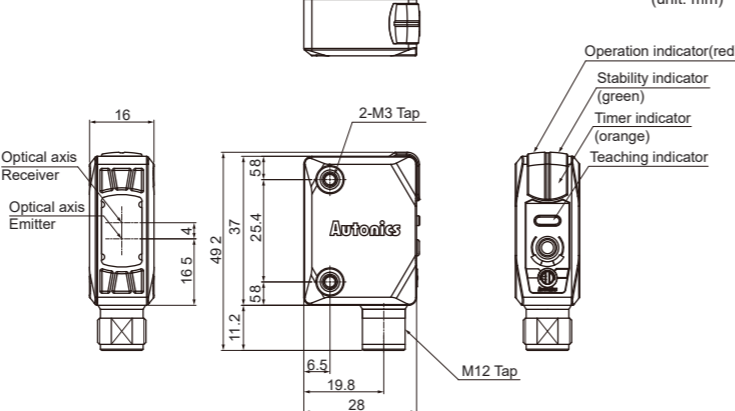

**■ Mounting Bracket**

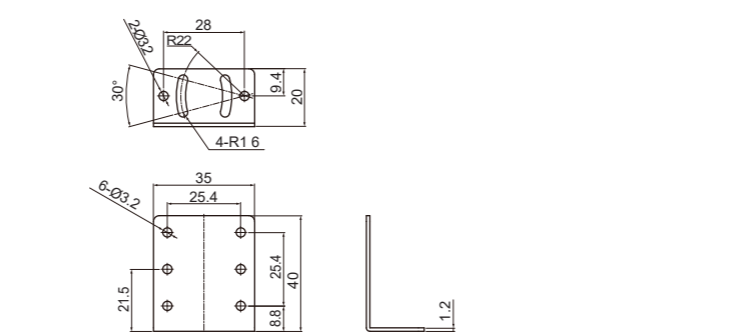

**■ Functions**

- **Color teaching**  
Set the reference color with the teaching function. Press the SET key in RUN mode to enter teaching standby status. Place the desired color at the sensing position (spot) and hold the SET key for over 3 seconds. When teaching is complete, the teaching color indicator will turn ON. When there is an error, the operation indicator will flash (red).
- **Display teaching**  
The set reference color can be displayed on the teaching indicator. With the ability to check the set reference color there is no need to re-set the teaching color every time. It may be difficult to check the similar colors when installing multiple sensors. Teaching indicator color is available only for reference.  
※The teaching color and the color displayed on the teaching indicator may differ depending on environment conditions (ambient light, reflection angle, material, etc.)
- **Sensing mode, sensitivity setting (color tolerance)**  
Two sensing modes; C (color only) mode discriminates by color rate and C+I (color +intensity) mode discriminates by color rate and contrast. Set the sensing sensitivity (fine, normal, rough) at each sensing mode.
- **Color match/mismatch mode**  
- Color match mode (N.O.): Output ON when target color matches reference color. Turn the color match/mismatch switch towards N.O.  
- Color mismatch mode (N.C.): Output ON when target color does not match reference color. Turn the color match/mismatch switch towards N.C.
- **OFF delay timer**  
Timer (40ms OFF delay) functions helps prevent output malfunction from target objects moving too rapidly. The timer indicator turns ON (orange) when the timer function is set.

**■ Operation and Settings**

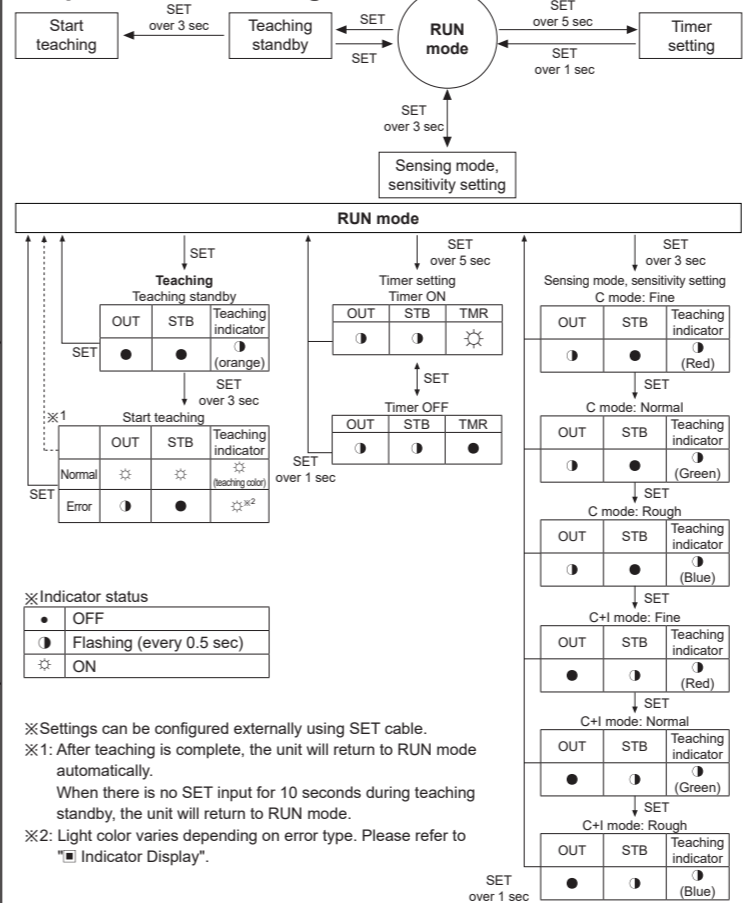

**■ Indicator Display**

Status		Operation indicator (Red LED)	Stability indicator (Green LED)	Teaching indicator (Full color LED)	Timer indicator (Orange LED)	
					Timer ON	Timer OFF
Normal operation	Stable match	☼	☼			
	Unstable match	☼	●			
	Unstable mismatch	●	●	☼ (Teaching color)		
	Stable mismatch	●	☼			
Sensitivity setting (C mode)	Fine			◐ (Red)		
	Normal			◐ (Green)		
	Rough			◐ (Blue)		
Sensitivity setting (C+I mode)	Fine			◐ (Red)	☼	●
	Normal			◐ (Green)		
	Rough			◐ (Blue)		
Teaching setting	Teaching standby	●	●	◐ (Orange)		
	Normal teaching	☼	☼	☼ (Teaching color)		
	Teaching error	◐	●	☼ (Green)		
	Fluctuating light intensity	◐	●	☼ (Red)		
Timer setting	ON	◐	◐	☼ (Teaching color)	☼	●
	OFF	◐	◐	☼ (Teaching color)	●	●
Overcurrent input		◐	◐	●	●	●

※Indicator status

☼	ON	●	OFF
◐	Flashing (every 0.5 sec)	◐◐	Flashing alternately (every 0.5 sec)

**■ Operation Mode**

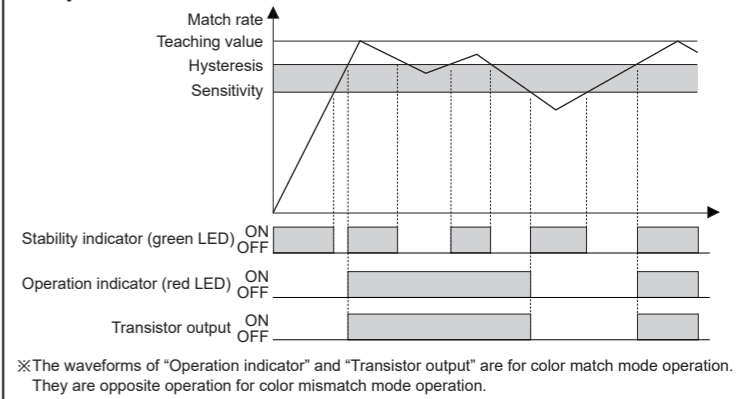

**■ Installation and Adjustment**

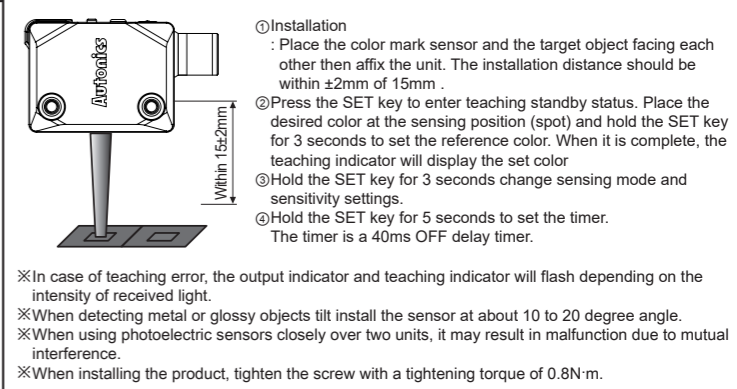

**■ Troubleshooting**

Problem	Cause	Troubleshooting
Will not operate	Power supply Connection error	Supply power within rated specifications Check the cable connections.
Will not operate occasionally	Excess light intensity alarm during teaching, output chattering	Install the sensor at a 10 to 20 degree angle. (when sensing metal or glossy objects)
	Converter external light interference	Install a visor on the sensor or install the unit away from the external light source.
Other error	Contamination of sensor cover	Remove the substance using a soft brush and reset the sensitivity.
	Connector error	Check connector assembly.
		Check the display status of the indicators.

**■ Cautions during Use**

1. Follow instructions in 'Cautions during Use'. Otherwise, it may cause unexpected accidents.
2. When connecting a DC relay or other inductive load to the output, remove surge by using diodes or varistors.
3. Use the product, 0.5 sec after supplying power. When using separate power supply for the sensor and load, supply power to sensor first.
4. 12-24VDC power supply should be insulated and limited voltage/current or Class 2, SELV power supply device.
5. Wire as short as possible and keep away from high voltage lines or power lines, to prevent inductive noise.
6. When using switching mode power supply to supply the power, ground F.G. terminal and connect a condenser between 0V and F.G. terminal to remove noise.
7. When using sensor with the equipment which generates noise (switching regulator, inverter, servo motor, etc.), ground F.G. terminal of the equipment.
8. This unit may be used in the following environments.
  - ①Indoors (in the environment condition rated in 'Specifications')
  - ②Altitude max. 2,000m
  - ③Pollution degree 2
  - ④Installation category II

**■ Major Products**

- Photoelectric Sensors
- Fiber Optic Sensors
- Door Sensors
- Door Side Sensors
- Area Sensors
- Proximity Sensors
- Pressure Sensors
- Rotary Encoders
- Connectors/Sockets
- Switching Mode Power Supplies
- Control Switches/Lamps/Buzzers
- I/O Terminal Blocks & Cables
- Stepper Motors/Drivers/Motion Controllers
- Graphic/Logic Panels
- Field Network Devices
- Laser Marking System (Fiber, CO<sub>2</sub>, Nd: YAG)
- Laser Welding/Cutting System
- Temperature Controllers
- Temperature/Humidity Transducers
- SSRs/Power Controllers
- Counters
- Timers
- Panel Meters
- Tachometer/Pulse (Rate) Meters
- Display Units
- Sensor Controllers